

Model>Modelo:

MF-1908

Parts List:

No	A(1PC)	B (1PC)	C1(2PC)	C2(2PC)	D(1PC)	E1(4PC)	E2(4PC)	F(1PC)	G1(2PC)	G2(2PC)
Photo										

Tools Not Included/Herramientas No Incluidas

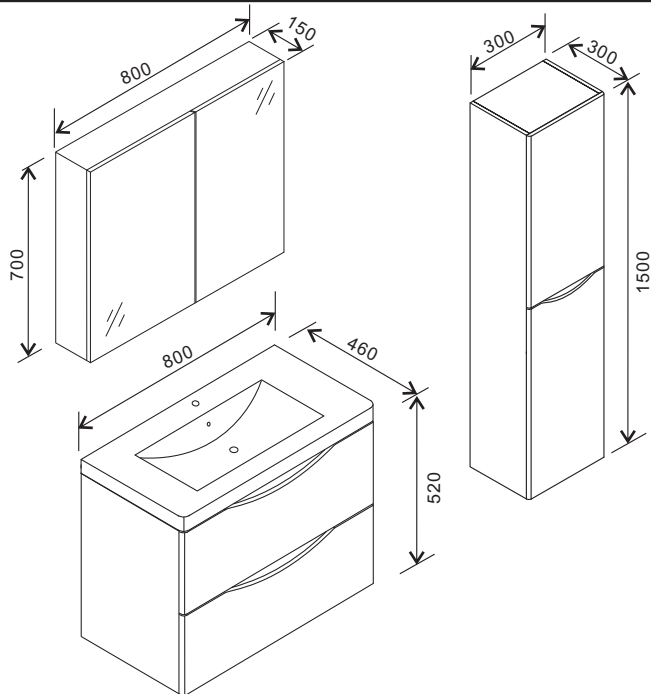
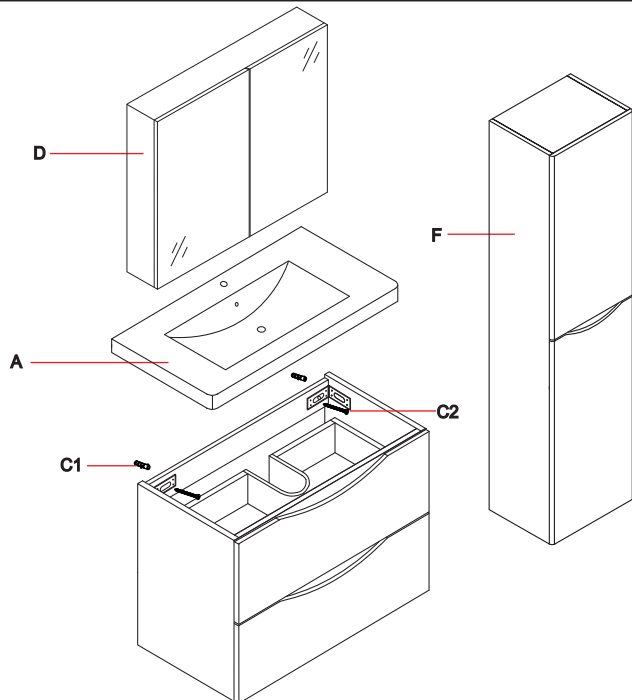

1. Install the cabinet on the wall using the screws (C1,C2) as below Picture.

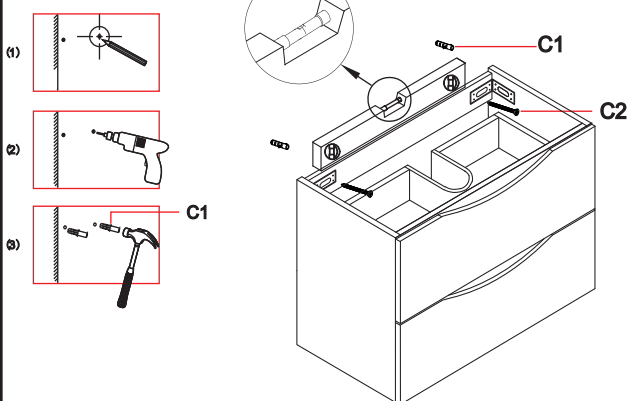

2. Put the basin (A) on the cabinet, then silicon the edges.

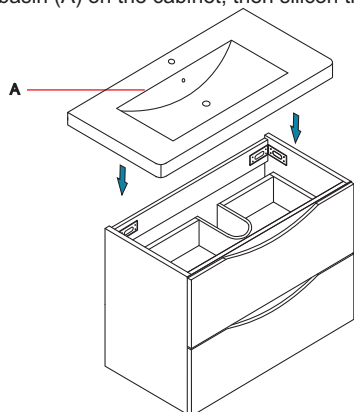

3. Install the mirror cabinet according to the diagram below

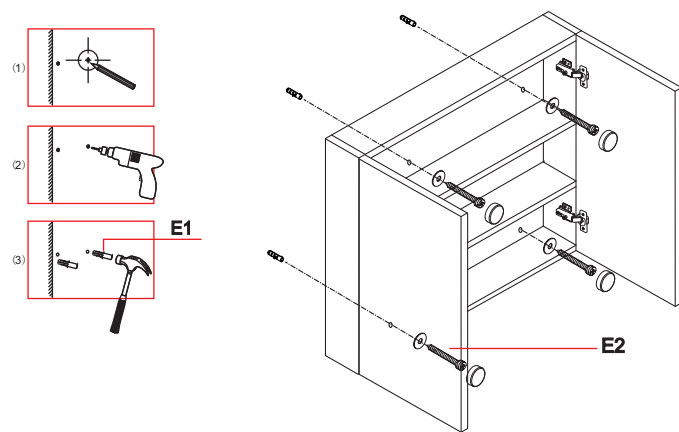

4. Install the side cabinet according to the diagram below

